

---

# **Bluetooth Module Datasheet**

**Model: HY-BTM875**

**Version: V1.1**

**2018-07-05**

**Shenzhen Huayang Xinke Electronics Co., Ltd**

**Mob: (086)13480952801**

**E-mail: [info@hyxkiot.com](mailto:info@hyxkiot.com)**

**Web: [www.hyxkiot.com](http://www.hyxkiot.com)**

**Baoan, Shenzhen**

---

---

# List of Contents

<b>1 Introduction</b>	<b>3</b>
<b>2 Key Features</b>	<b>3</b>
<b>3 Applications</b>	<b>4</b>
<b>4 Block Diagram</b>	<b>4</b>
<b>5 General specifications</b>	<b>4</b>
<b>6 Module Package Information</b>	<b>5</b>
<b>6.1 Pinout Diagram and package dimensions</b>	<b>5</b>
<b>6.2 Module Pin descriptions</b>	<b>6</b>
<b>7 Electrical Characteristics</b>	<b>9</b>
<b>7.1 Absolute Maximum Ratings</b>	<b>9</b>
<b>7.2 Recommended Operating Conditions</b>	<b>9</b>
<b>8 Recommended reflow temperature profile</b>	<b>10</b>

---

---

# 1 Introduction

**Shenzhen Huayang Xinke Electronics Co., Ltd** introduces the pioneer of the Bluetooth 5.0 modules HY-BTM875 which is a high performance, cost effective, low power and compact solution. The Bluetooth module provides a complete 2.4GHz Bluetooth system based on the CSR8675 BGA chipset which is a single chip radio and baseband IC for Bluetooth 2.4GHz systems,. This module is fully qualified single-chip dual mode Bluetooth@v5.0 system.

## 2 Key Features

### Bluetooth Profiles

- Bluetooth v5.0 specification support
- Qualcomm® Bluetooth® Low Energy secure connection
- A2DP v1.3.1
- AVRCP v1.6
- HFP v1.7
- HSP v1.2
- MAP v1.1
- PBAP v1.1.1
- DID v1.1
- QTIL's proximity pairing and QTIL's proximity connection

### Music Enhancements

- aptX, aptX Low Latency, SBC, and AAC audio codecs
- Qualcomm TrueWireless™ Stereo (TWS), which allows two devices to be configured as a stereo pair
- Configurable Signal Detection to trigger events
- 1 bank of up to 10-stage Speaker Parametric EQ
- 6 banks of up to 5-stage User Parametric EQ for music enhancement
- Qualcomm® meloD™ Expansion audio processing: 3D stereo widening
- Compressor to compress or expand the dynamic range of the audio
- Post Mastering to improve DAC fidelity
- Dual I²S outputs with crossover

### Additional Functionality

- Support for multi-language programmable audio prompts
- Multipoint support for A2DP connection to 2 A2DP sources for music playback
- Talk-time extension, which automatically reduces processor functions to extend use when a low battery condition is detected
- Slim module with 15mm x 22mm x 2.5mm

### 3 Applications

- Stereo Headsets
- Wired Stereo headsets and headphones
- Portable Bluetooth Stereo speakers

### 4 Block Diagram

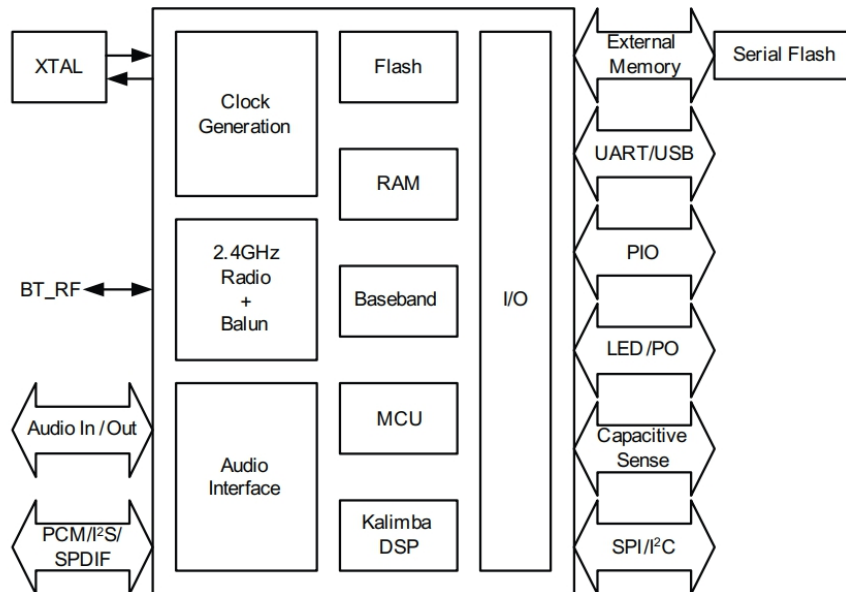

### 5 General specifications

<b>Model Name</b>	<b>HY-BTM875</b>
<b>Product Description</b>	<b>Bluetooth 5.0 Class2 Module</b>
Bluetooth Standard	Bluetooth 5.0
Chipset	CSR8675 BGA
Dimension	15mm x 22mm x 2.5mm
<b>Operating Conditions</b>	
Voltage	2.8~4.2V
Temperature	-10~+70°C
Storage Temperature	-40~+85°C
<b>Electrical Specifications</b>	
Frequency Range	2402~2480MHz
Maximum RF Transmit Power	9dBm
$\pi/4$ DQPSK Receive Sensitivity	-91dBm
8DPSK Receive Sensitivity	-81dBm

## 6 Module Package Information

### 6.1 Pinout Diagram and package dimensions

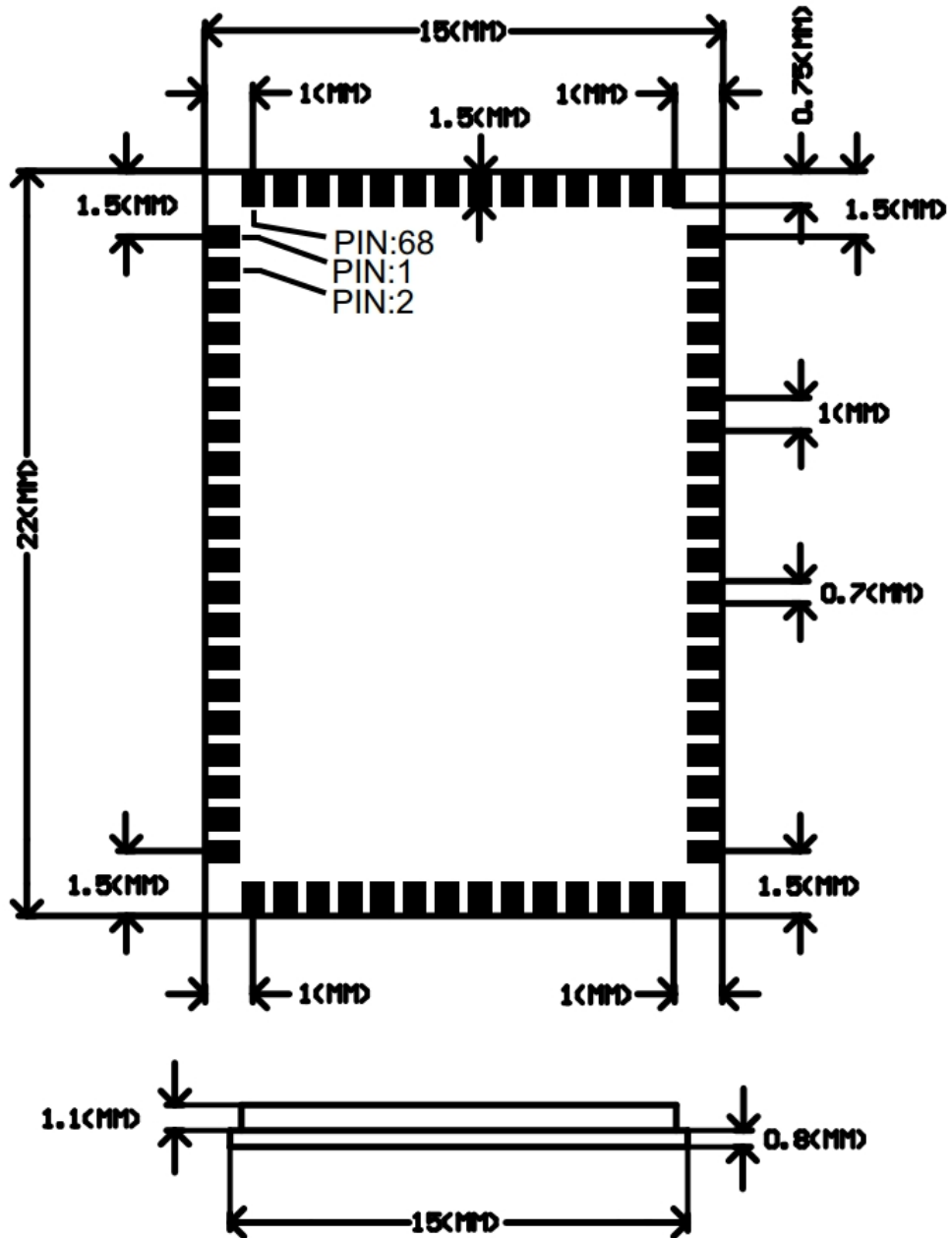

Note: Tolerance without mark default  $\pm 0.05$ mm  
尺寸未标注公差处公差为 $\pm 0.05$ mm

Unit: MM

Recommended PCB layout footprint

## 6.2 Module Pin descriptions

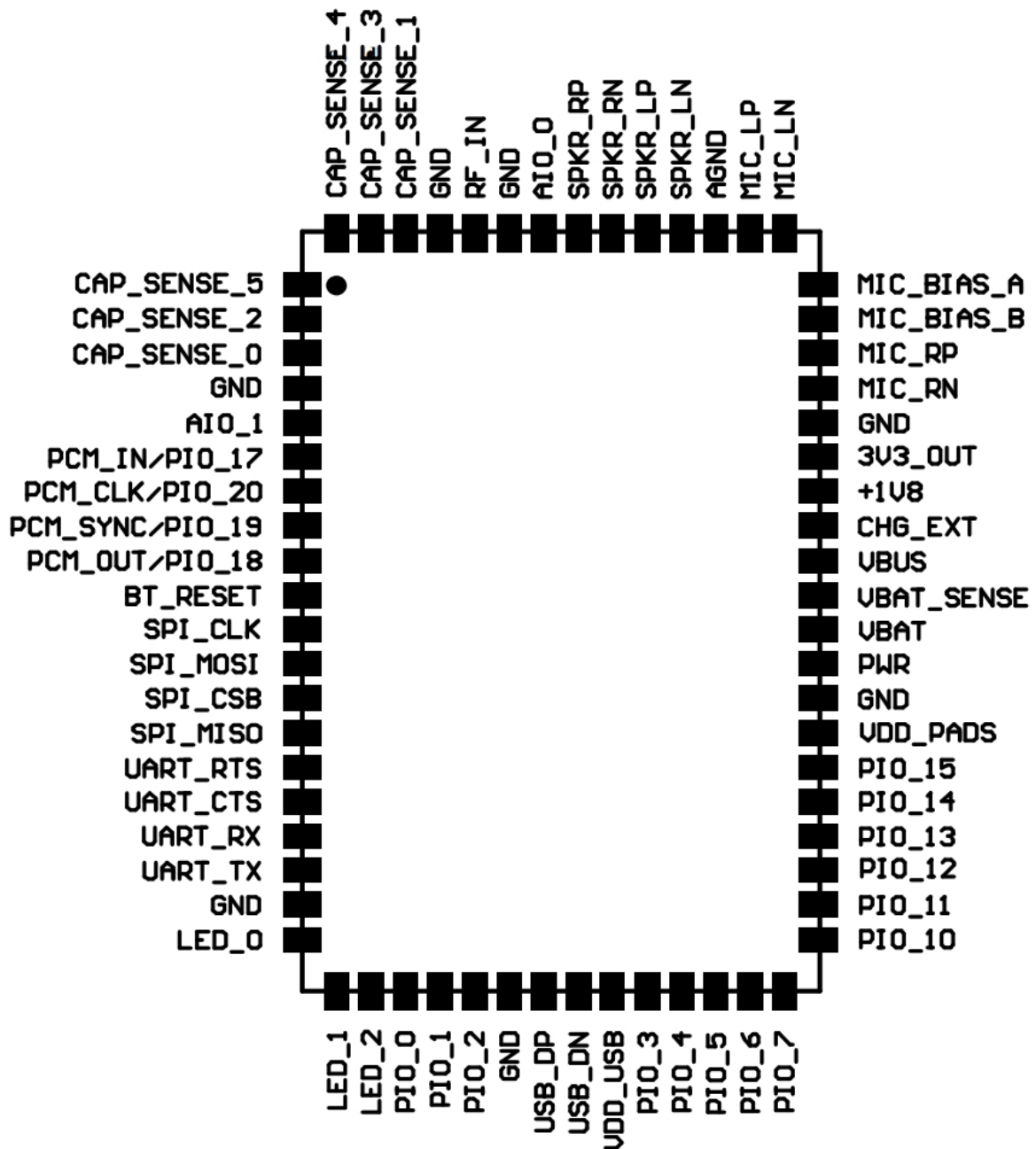

Pin#	Pin Name	Pin Type	Description
1	CAP_SENSE_5	Analogue input	Capacitive touch sensor input
2	CAP_SENSE_2	Analogue input	Capacitive touch sensor input
3	CAP_SENSE_0	Analogue input	Capacitive touch sensor input
4	GND	Ground	Digital Ground
5	AIO_1	Bi-directional	Analogue programmable input / output line
6	PCM_IN/PIO_17	Bi-directional with weak pull_down	Synchronous data input.Alternative function PIO[17]
7	PCM_CLK/PIO_20	Bi-directional with weak pull_down	Synchronous data clock.Alternative function PIO[20]
8	PCM_SYNC/PIO_19	Bi-directional with weak pull_down	Synchronous data sync.Alternative function PIO[19]

9	PCM_OUT/PIO_18	Bi-directional with weak pull_down	Synchronous data output.Alternative function PIO[18]
10	BT_RESET	Input with strong pull-up	Reset if low.Input debounced so must be low for >5ms to cause a reset
11	SPI_CLK	Input with weak pull-down	SPI Clock
12	SPI_MOSI	Input with weak pull-down	SPI data input
13	SPI_CSB	Input with strong pull-up	Chip select for SPI,active low
14	SPI_MISO	Output with weak pull-down	SPI data output
15	UART_RTS	Bi-directional with weak pull_up	UART request to send,active low.Alternative function PIO[16]
16	UART_CTS	Bi-directional with weak pull_down	UART clear to send,active low
17	UART_RX	Bi-directional with strong pull_up	UART data input
18	UART_TX	Bi-directional with weak pull_up	UART data output
19	GND	Ground	Digital Ground
20	LED_0	Open drain	LED driver Alternative function PIO[29]
21	LED_1	Open drain	LED driver Alternative function PIO[30]
22	LED_2	Open drain	LED driver Alternative function PIO[31]
23	PIO_0	Bi-directional with weak pull_down	Programmable input/output line
24	PIO_1	Bi-directional with weak pull_down	Programmable input/output line
25	PIO_2	Bi-directional with weak pull_down	Programmable input/output line
26	GND	Ground	Digital Ground
27	USB_DP	Bi-directional	USB data plus with selectable internal 1.5kohm pull-up resistor
28	USB_DN	Bi-directional	USB data minus
29	VDD_USB	NC	Positive supply for USB ports
30	PIO_3	Bi-directional with weak pull_down	Programmable input/output line
31	PIO_4	Bi-directional with weak pull_down	Programmable input/output line
32	PIO_5	Bi-directional with weak pull_down	Programmable input/output line
33	PIO_6	Bi-directional with weak pull_down	Programmable input/output line
34	PIO_7	Bi-directional with weak pull_down	Programmable input/output line
35	PIO_10	Bi-directional with weak pull_down	Programmable input/output line
36	PIO_11	Bi-directional with weak pull_down	Programmable input/output line
37	PIO_12	Bi-directional with weak pull_down	Programmable input/output line
38	PIO_13	Bi-directional with weak pull_down	Programmable input/output line
39	PIO_14	Bi-directional with weak pull_down	Programmable input/output line
40	PIO_15	Bi-directional with weak pull_down	Programmable input/output line
41	VDD_PADS	Analogue in	positive supply input for digital input/output ports PIOx
42	GND	Ground	Digital Ground
43	PWR	Input enable	Regulator enable input. Can also be sensed as an input. Regulator enable and multifunction button. A high input (tolerant to VBAT) enables the on-chip regulators, which can then be latched on internally and the button used as a multifunction input.
44	VBAT	Power supply	Battery positive terminal
45	VBAT_SENSE	NC	Battery charger sense input
46	VBUS	Power supply	Alternative supply via bypass regulator for 1.8V and 1.35V switchmode power supply regulator inputs. Must

			be connected to the same potential as VOUT_3V3.
47	CHG_EXT	NC	External battery charger control
48	+1V8	Open drain output	LED driver
49	3V3_OUT	Analogue out	3.3V bypass linear regulator output
50	GND	Ground	Digital Ground
51	MIC_RN	Analogue in	Microphone input negative,right
52	MIC_RP	Analogue in	Microphone input positive,right
53	MIC_BIAS_B	Analogue out	Microphone bias B
54	MIC_BIAS_A	Analogue out	Microphone bias A
55	MIC_LN	Analogue in	Microphone input negative,left
56	MIC_LP	Analogue in	Microphone input positive,left
57	AGND	Ground	Analogue Ground
58	SPKR_LN	Analogue out	Speaker output negative,left
59	SPKR_LP	Analogue out	Speaker output positive,left
60	SPKR_RN	Analogue out	Speaker output negative,right
61	SPKR_RP	Analogue out	Speaker output positive,right
62	AIO_0	Bi-directional	Analogue programmable input / output line
63	GND	Ground	Analogue Ground
64	RF_IN	RF	Bluetooth 50ohm transmitter output/receiver input
65	GND	Ground	Analogue Ground
66	CAP_SENSE_1	Analogue input	Capacitive touch sensor input
67	CAP_SENSE_3	Analogue input	Capacitive touch sensor input
68	CAP_SENSE_4	Analogue input	Capacitive touch sensor input



---

---

## 7 Electrical Characteristics

### 7.1 Absolute Maximum Ratings

Rating	Minimum	Maximum
Storage temperature	-40°C	+85°C

### 7.2 Recommended Operating Conditions

Operating Condition	Minimum	Maximum
Operating temperature range	-10°C	+70°C
Supply voltage: VBAT	+2.8V	+4.2V

## 8 Recommended reflow temperature profile

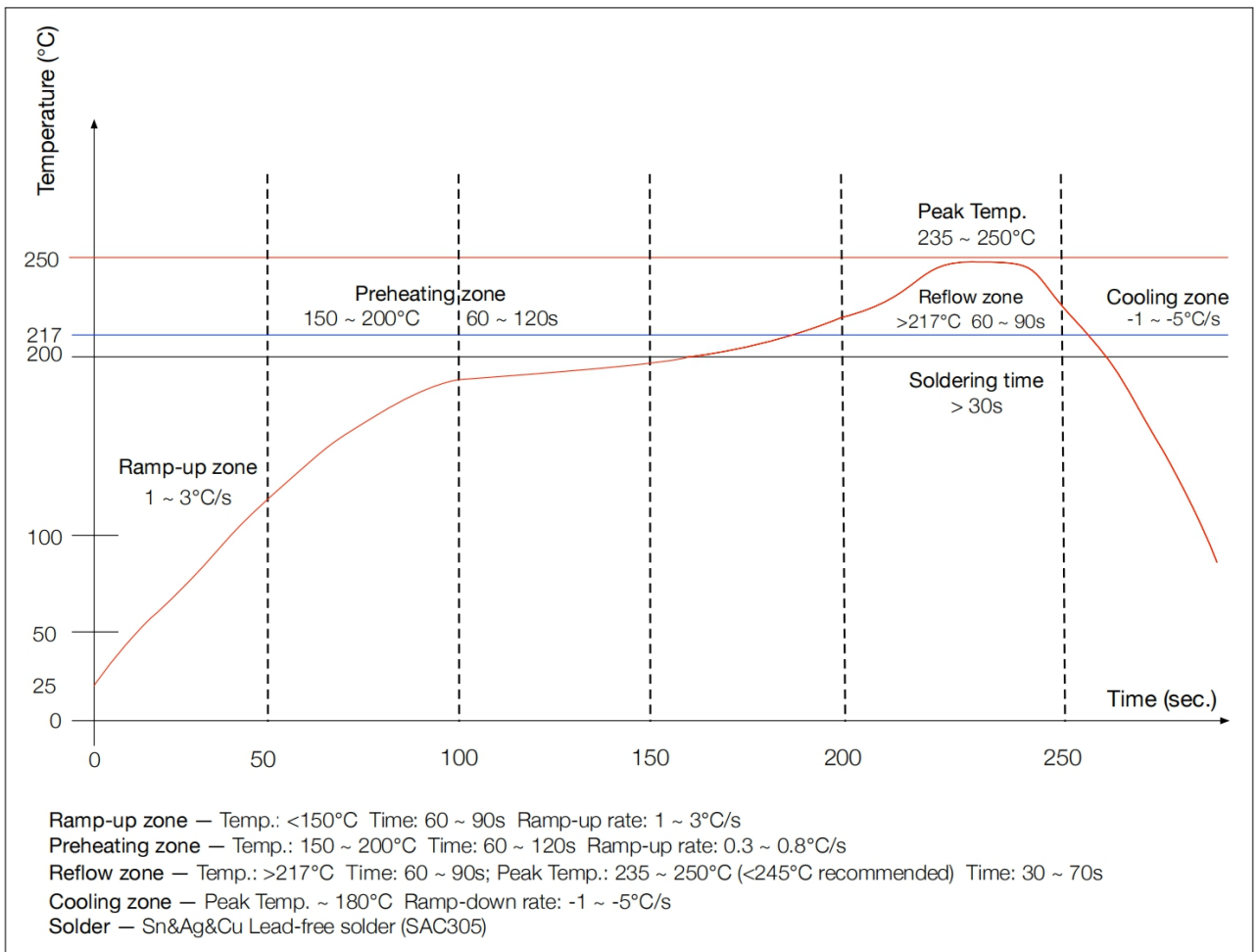

**The module Must go through 125°C baking for at least 9 hours before SMT AND IR reflow process!**

---

---

## Record of Changes

Data	Revision	Description
2013-01-30	V1.0	Original publication of this document.
2018-07-05	V1.1	Update Bluetooth version.

**Mob/ WhatsApp: (086) 13480952801**

**Web: [www.hyxkiot.com](http://www.hyxkiot.com)**

**E-mail: [info@hyxkiot.com](mailto:info@hyxkiot.com)**